

Konvektionsluft regulierbar
Convection air control
Contrôle de l'air de convection

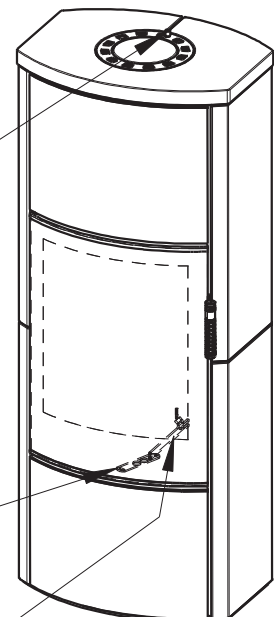

Primärluft
Sekundärluft
Tertiärluft
Primary air
Secondary air
Tertiary air
Air primaire
Air secondaire
Air tertiaire

Rostzugstange
Grate lever
Lever à grille

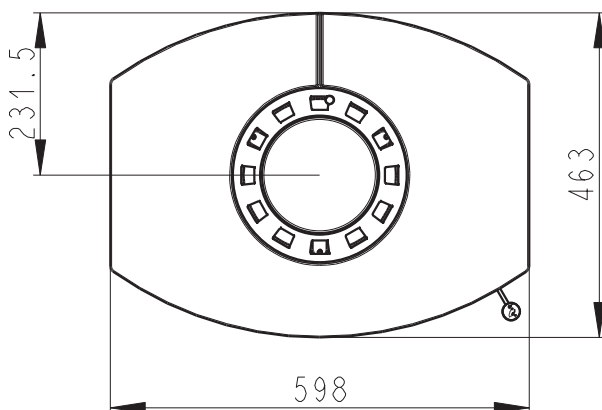

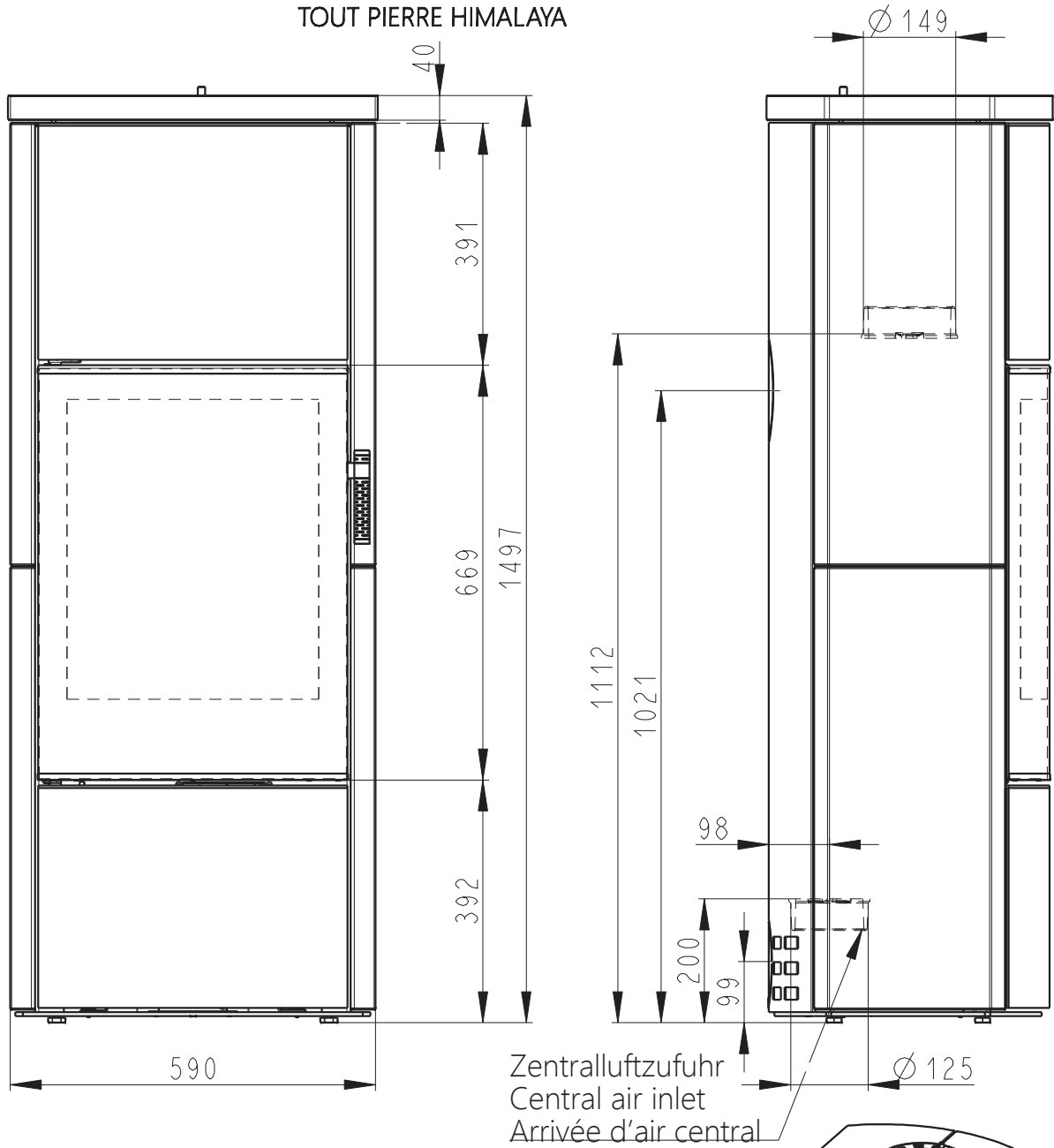

Konvektionsluft regulierbar
Convection air control
Contrôle de l'air de convection

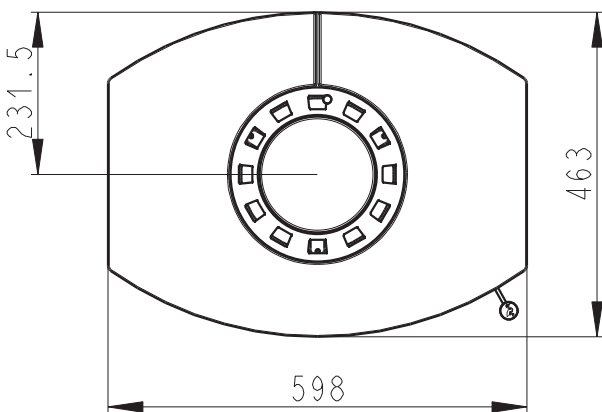

Primärluft
Sekundärluft
Tertiärluft
Primary air
Secondary air
Tertiary air
Air primaire
Air secondaire
Air tertiaire

Rostzugstange
Grate lever
Lever à grille

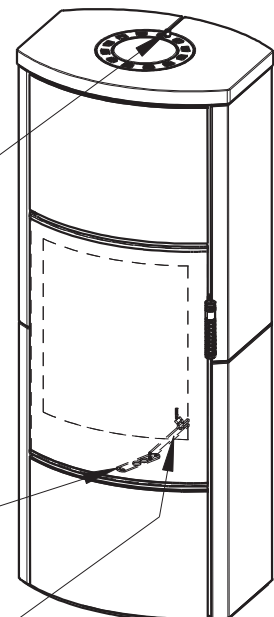

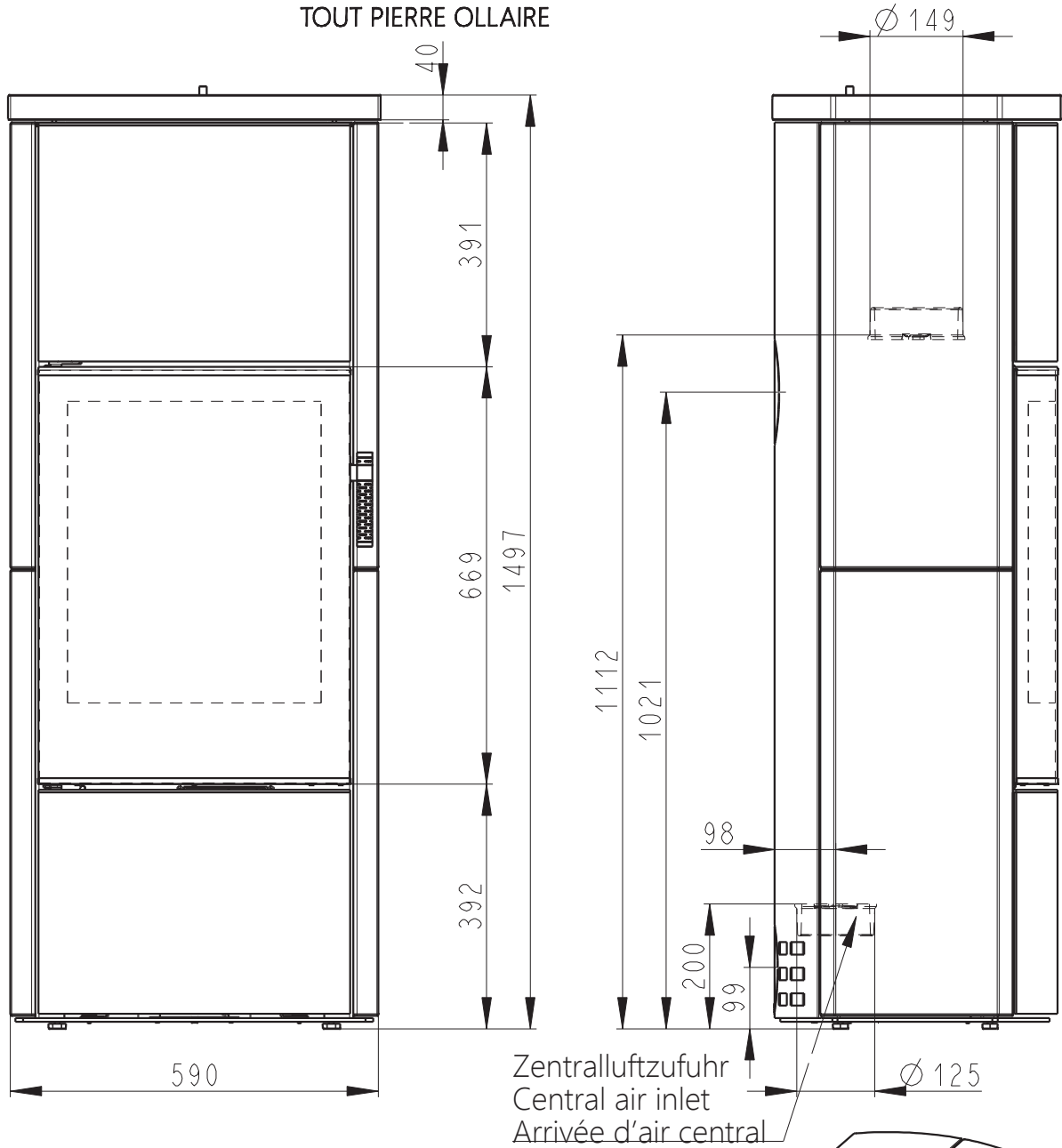

Konvektionsluft regulierbar
Convection air control
Contrôle de l'air de convection

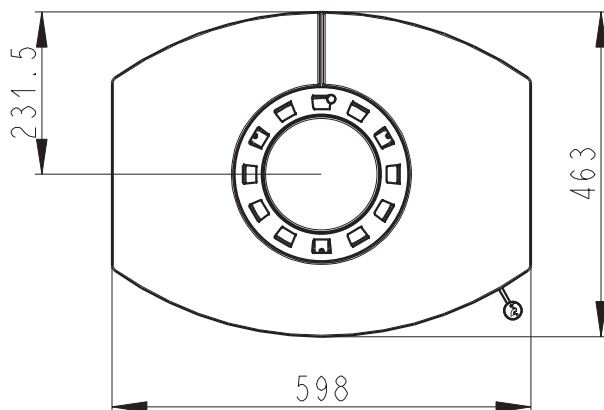

Primärluft
Sekundärluft
Tertiärluft
Primary air
Secondary air
Tertiary air
Air primaire
Air secondaire
Air tertiaire

Rostzugstange
Grate lever
Lever à grille

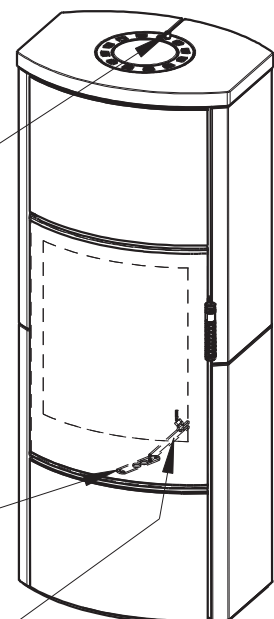

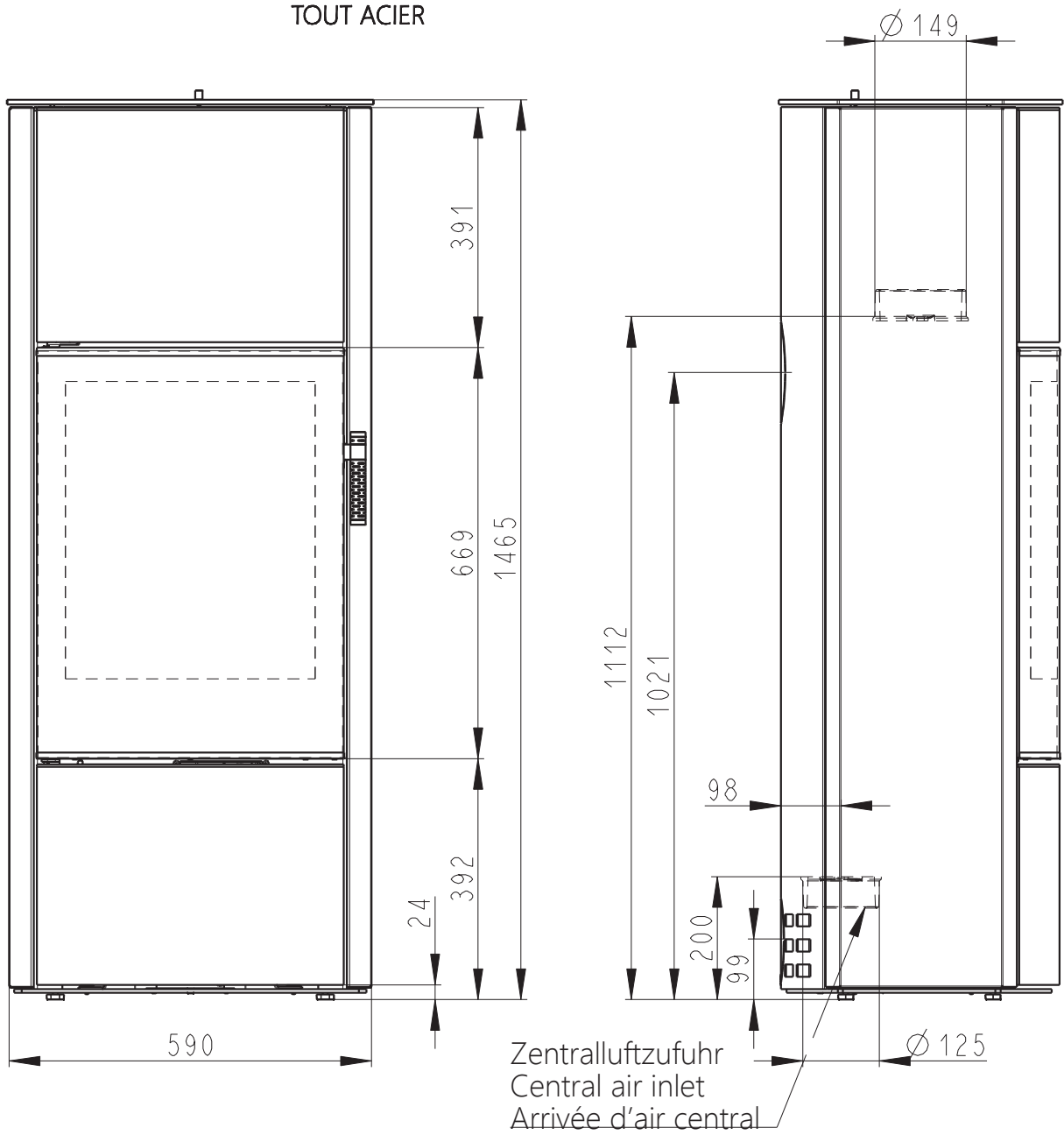

Konvektionsluft regulierbar
Convection air control
Contrôle de l'air de convection

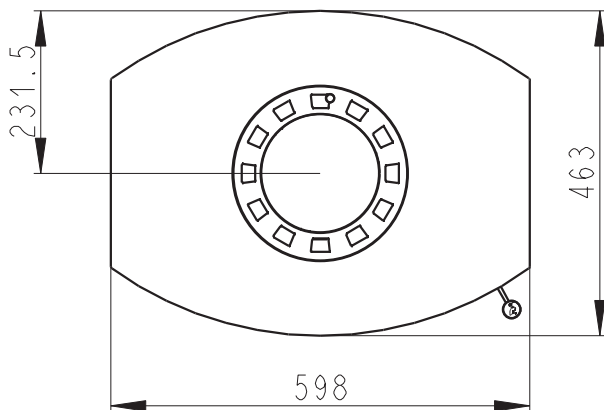

Primärluft
Sekundärluft
Tertiärluft
Primary air
Secondary air
Tertiary air
Air primaire
Air secondaire
Air tertiaire

Rostzugstange
Grate lever
Lever à grille

